

Manometer-Aufschraubstutzen
Adjustable gauge coupling with sealing ring
Union simple femelle pour manomètre (corps)

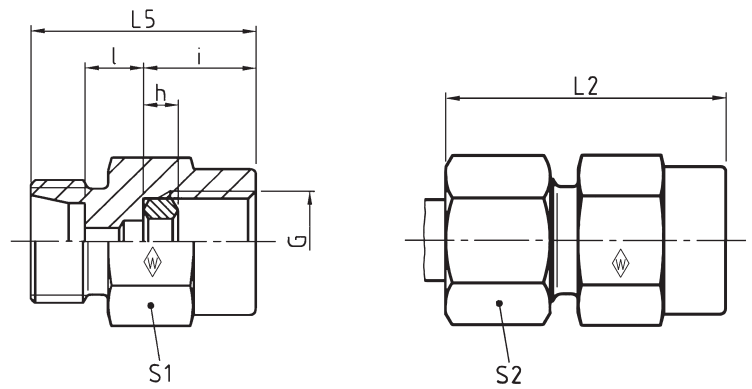

MAS R

Whitworth-Rohrgewinde
BSP thread
Filetage Whitworth



DIN-ISO 228 (R ..., DIN 259)

Reihe Series Série	PN bar (psi)	Rohr-AD Tube OD Tube Ø ext.	G	Typ Type Designation	Best.-Nr. Reference R f.	kg per 100 St. kg per 100 pcs. kg par 100 p.	L ₂	L ₅	l	i	h	S ₁	S ₂
L	500 (7252)	6	G 1/4	MAS 6 LR	066939	3,8	37	14,5	7,5	14,5	4,5	19	14
		8	G 1/4	MAS 8 LR	066940	3,6	37	14,5	7,5	14,5	4,5	19	17
		10	G 1/4	MAS 10 LR	067370	4,0	38	15,5	8,5	14,5	4,5	19	19
	400 (5801)	12	G 1/4	MAS 12 LR	066941	6,3	38	15,5	8,5	14,5	4,5	19	22
S	800 (11603)	6	G 1/2	MAS 6 SR	066942	9,4	46	18x	11	20	5	27	17
		8	G 1/2	MAS 8 SR	066943	9,0	46	18	11	20	5	27	19
		10	G 1/2	MAS 10 SR	066944	9,0	47	18	10,5	20	5	27	22
	630 (9137)	12	G 1/2	MAS 12 SR	066945	9,5	47	18	10,5	20	5	27	24

L₂ = Ungefährmaß bei angezogener Überwurfmutter
L₂ = approximate length with nut tightened
L₂ = longueur approximative, l'écrou étant bloqué

